

Your Super Simple Guide to Setting Up Your Canopy™ Desk

HARDCOAT
Durable Top Coat by **valspar**

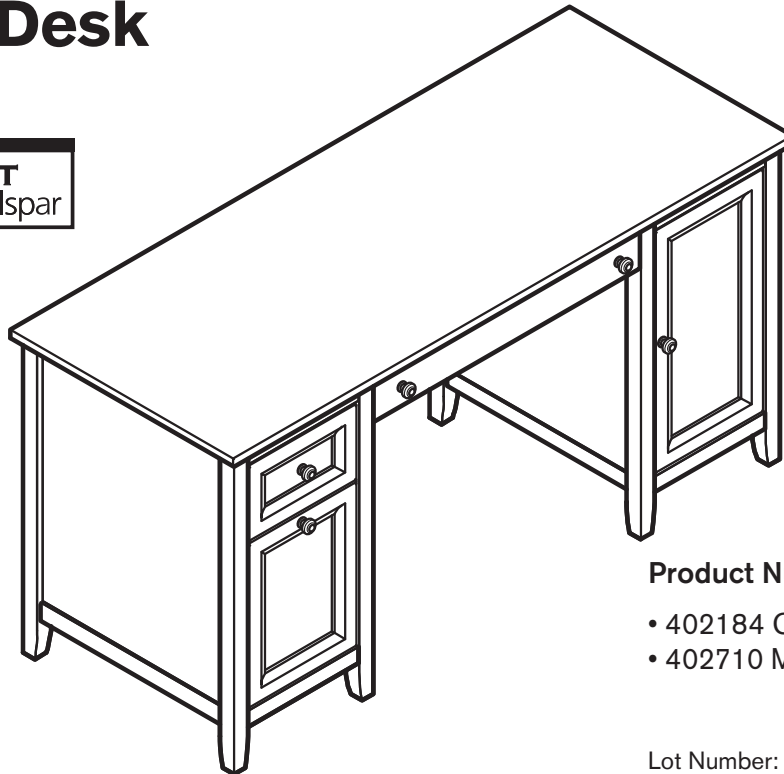

Product Number: NAH2006c

- 402184 Chestnut Finish
- 402710 Mahogany Finish

Lot Number: _____
Date Purchased: ____/____/____

About Canopy™ Furniture

Decorating your home should be fun and easy. The classic styles of the Canopy™ Cornerstone Collection are designed to work beautifully together and fit right in with your existing furniture.

Here for the Long Haul. Every piece in the Canopy Cornerstone Collection is built of solid hardwood and genuine birch veneer, a construction that increases the furniture's strength and durability.

Stands Up to Real Life. A multi-step finishing process adds depth and clarity to the wood. For added strength, we finish each piece with a topcoat of HardCoat, made for us by Valspar, a leader in coatings for fine furniture.

No worries. Sticky fingers, doggie drool, spilled milk. Life can get messy. Canopy furniture is built to stand up to nearly everything a busy household throws at it.

Works hard. Canopy furniture works as hard as you do. Many of the pieces in our collection can multi-task from room-to-room to adapt to the changing needs of your home (or follow the whims of new design and decorating ideas).

The Canopy team would like to thank you for your purchase. Inspired by real life, Canopy furniture will be welcome in your home for years to come. So put your feet up and relax!

This set-up guide contains **important** safety information; please read and keep it for future reference.

NEED HELP? For help with assembly or if you are missing a part, please call the **Sauder Woodworking Co.** 1-800-523-3987 (7 a.m. to 5 p.m. PST).

Canopy Desk



Get Ready!

Our furniture uses an innovative, patent-pending, quick assembly method. We tested and assembled every piece ourselves to make sure it's truly easy.

- We recommend two people to assemble this item – so grab a friend to help!
- Please read all the instructions before starting.
- Carefully unpack and identify each part, component, and piece of hardware to make sure you have everything you need for assembly. Lay out each part on a soft, uncluttered surface.



! Important: We suggest you use a rubber mallet, but you can also use a hammer. Either way, cushion the pieces with the included wood block to protect the furniture finish.

Desk Parts

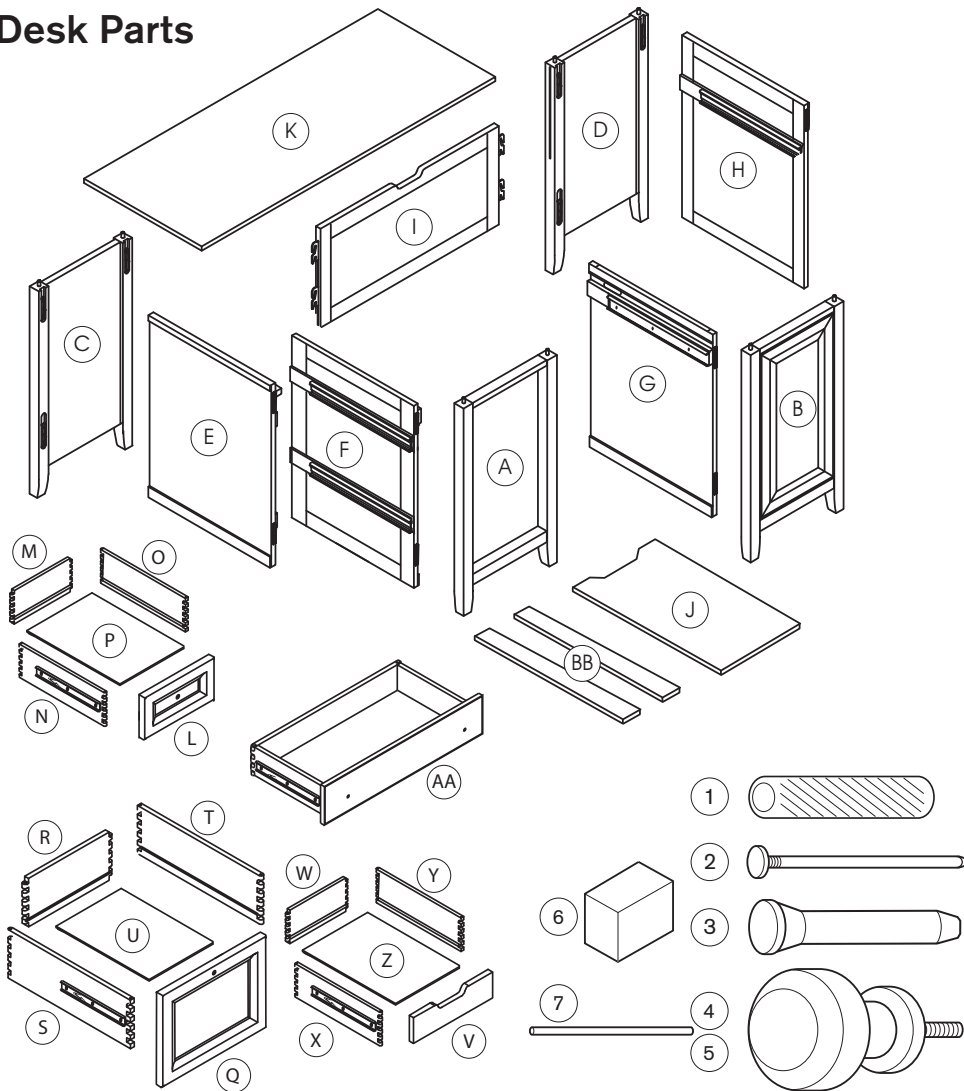

COMPONENTS

PART	QTY
(A) Left Front Panel	1
(B) Right Front Panel	1
(C) Left Rear Panel	1
(D) Right Rear Panel	1
(E) Left Outer Panel	1
(F) Left Inner Panel	1
(G) Right Inner Panel	1
(H) Right Outer Panel	1
(I) Rear Panel	1
(J) Bottom Shelf	1
(K) Top Panel	1
(AA) Center Drawer	1
(BB) Bottom Slats	2

DRAWER PARTS LIST

Top Drawer:

(L) Front Panel	1
(M) Rear Panel	1
(N) Left Panel	1
(O) Right Panel	1
(P) Bottom Panel	1

Bottom Drawer:

(Q) Front Panel	1
(R) Rear Panel	1
(S) Left Panel	1
(T) Right Panel	1
(U) Bottom Panel	1

Right Drawer:

(V) Front Panel	1
(W) Rear Panel	1
(X) Left Panel	1
(Y) Right Panel	1
(Z) Bottom Panel	1

HARDWARE

PART	QTY
(1) Wood Dowels	8
(2) Long Drawer Pins	24
(3) Retainer Pins	8
(4) (5) Wood and Metal Knobs	5ea
(6) Wood Block (to protect wood)	1
(7) File Rod	2

NEED HELP? For help with assembly or if you are missing a part, please call the **Sauder Woodworking Co.** 1-800-523-3987 (7 a.m. to 5 p.m. PST). Make sure you have the name of the missing part so we can replace it quickly. For returns, visit www.walmart.com and follow the steps to return a product. You can also download assembly instructions at www.walmart.com/canopy.

Step 1: Assemble Left Side of Desk

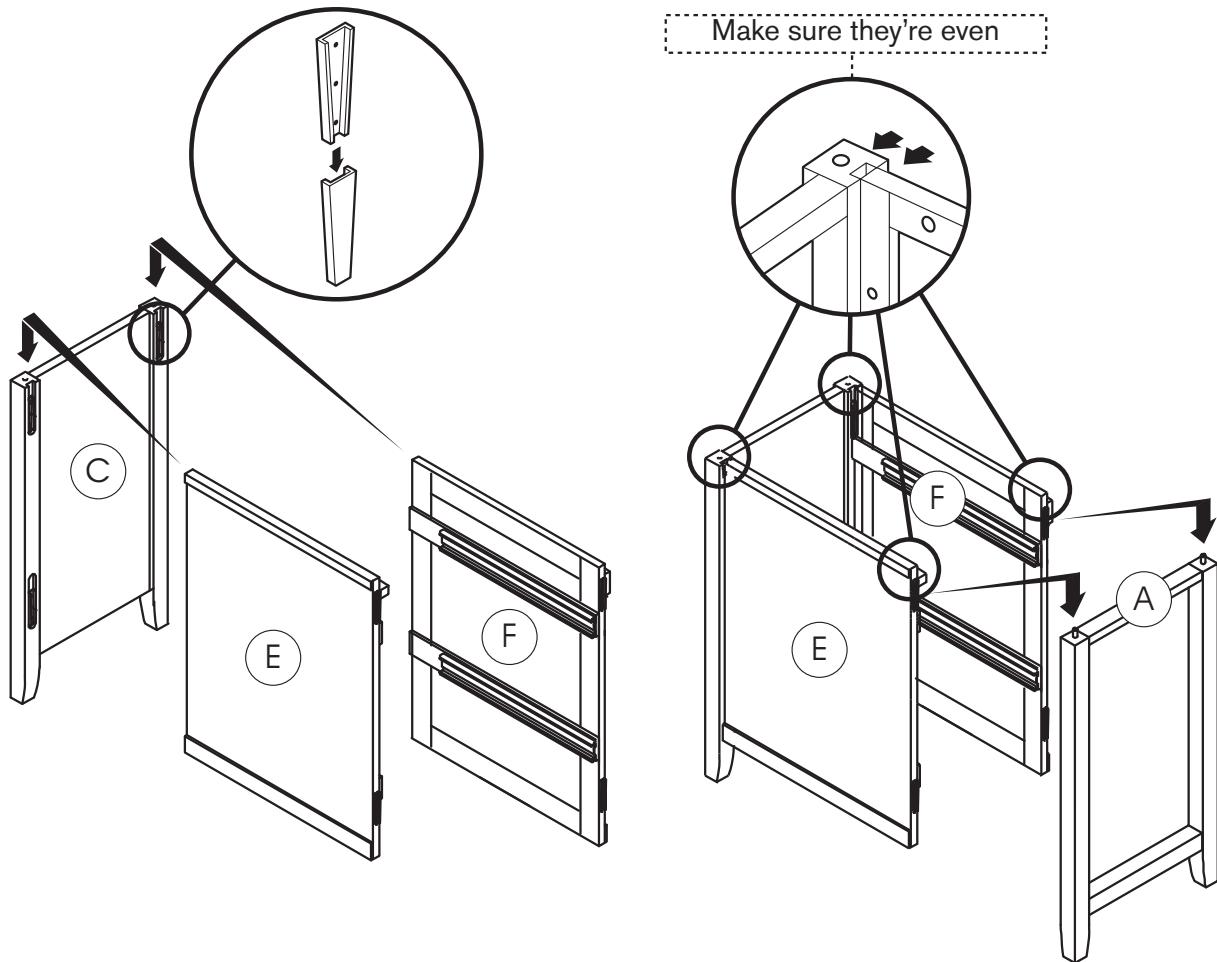

1. Place brackets on left outer panel (E) and left inner panel (F) into slots in left rear panel (C).
2. Push panels down until secure, but loose enough to remove.
3. Place brackets on left outer panel (E) and left inner panel (F) into slots in left front panel (A)
4. Make sure all brackets are inserted properly.
5. If necessary, position the wood block over the connecting points and gently tap the corners of the panels with a mallet or hammer until edges of panels are even and securely in place.

NEED HELP? For help with assembly or if you are missing a part, please call the **Sauder Woodworking Co.** 1-800-523-3987 (7 a.m. to 5 p.m. PST).

Step 2: Assemble Right Side of Desk

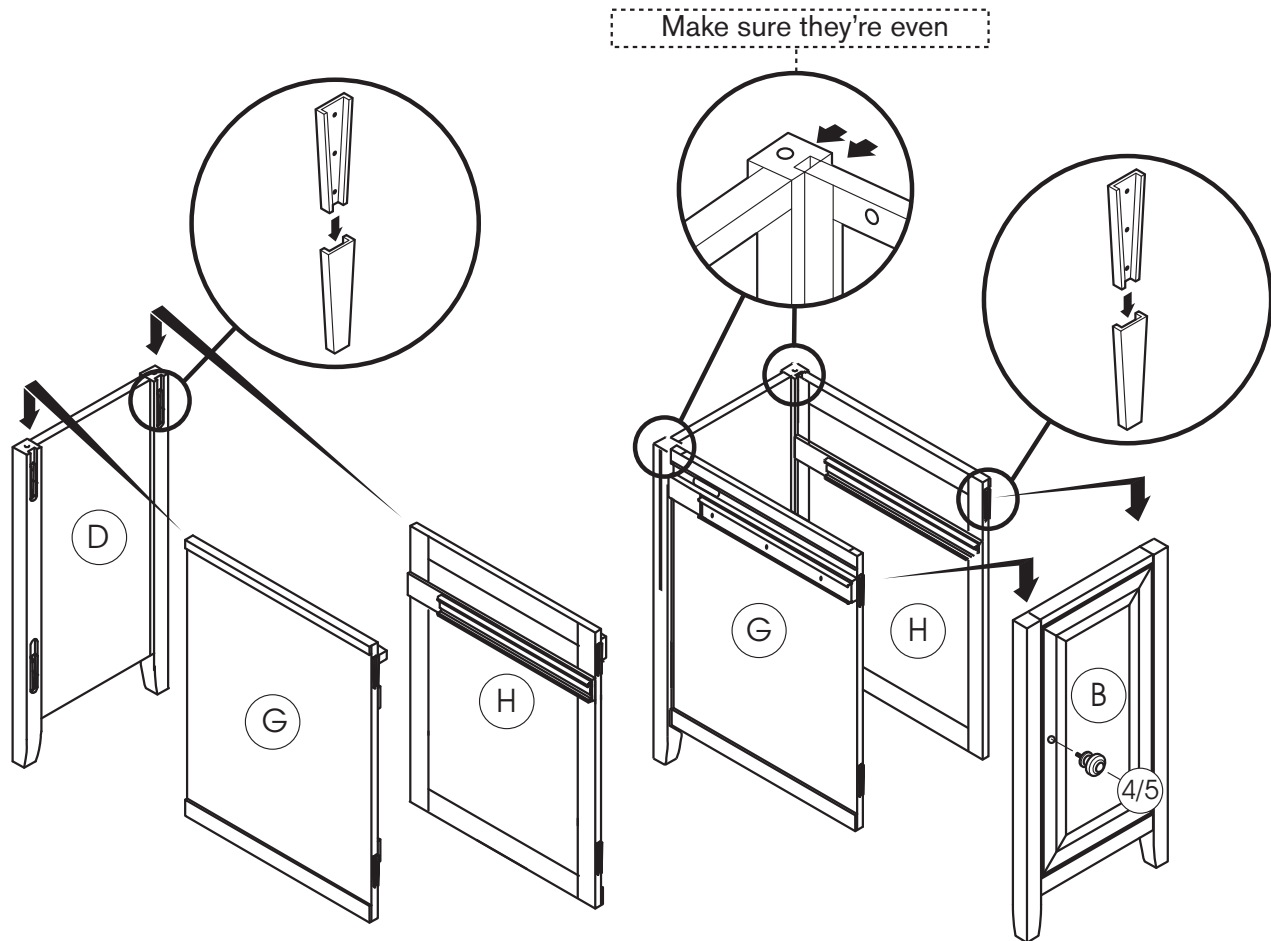

1. Place brackets on right inner panel (G) and right outer panel (H) into slots in right rear panel (D).
2. Push panels down until secure, but loose enough to remove.
3. Place brackets on right inner panel (G) and right outer panel (H) into slots in right front panel (B).
4. Make sure all brackets are inserted properly.
5. If necessary, position the wood block over the connecting points and gently tap the corners of the panels with a mallet or hammer until edges of panels are even and securely in place.
6. Select a wood or metal knob (4) or (5) and screw into door.

NEED HELP? For help with assembly or if you are missing a part, please call the **Sauder Woodworking Co.** 1-800-523-3987 (7 a.m. to 5 p.m. PST).

Step 3: Connect Left and Right Sides of Desk

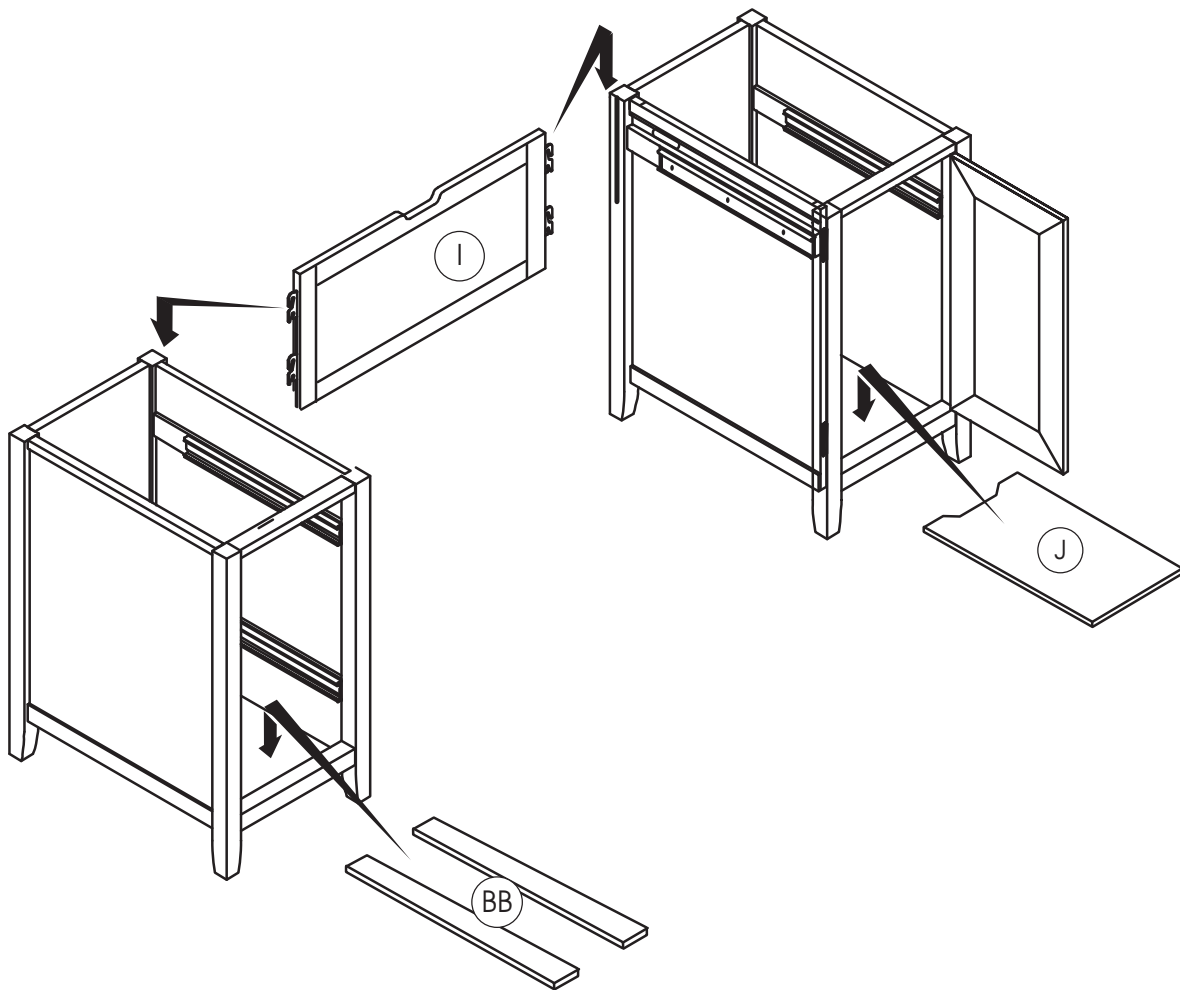

1. Attach rear panel (I) to left and right side of desk.
2. Place bottom shelf (J) into right side of desk.
3. Place bottom slats (BB) into left side of desk.

NEED HELP? For help with assembly or if you are missing a part, please call the **Sauder Woodworking Co.** 1-800-523-3987 (7 a.m. to 5 p.m. PST).

Step 4: Assemble Top Drawer

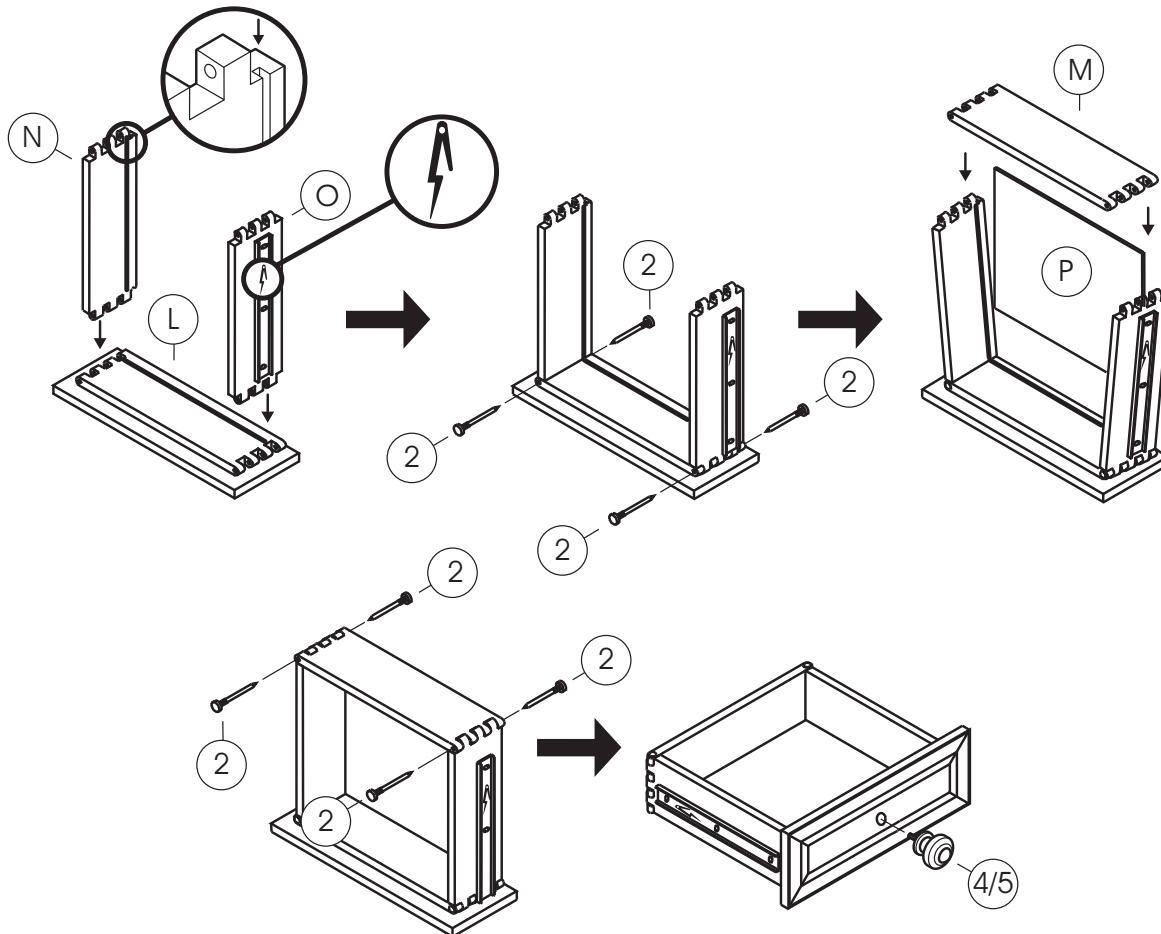
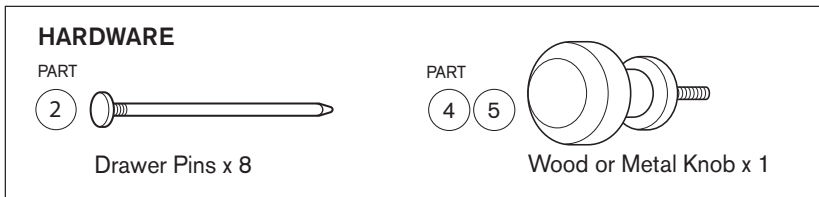

1. Connect left and right drawer panels (N) and (O) to front drawer panel (L) using four drawer pins (2). Make sure black side latches are pointing forward.
2. Slide bottom drawer panel (P) into slots.
3. Connect rear drawer panel (M) to left and right panels using four drawer pins (2). If necessary, gently tap pins with a mallet or hammer until secure.
4. Select a wood or metal knob (4) or (5) and screw into front drawer panel.

NEED HELP? For help with assembly or if you are missing a part, please call the **Sauder Woodworking Co.** 1-800-523-3987 (7 a.m. to 5 p.m. PST).

Step 5: Assemble Bottom Drawer

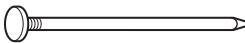
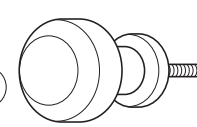
HARDWARE	
PART	PART
(2)	(4) (5)
	
Drawer Pins x 8	Wood or Metal Knob x 1

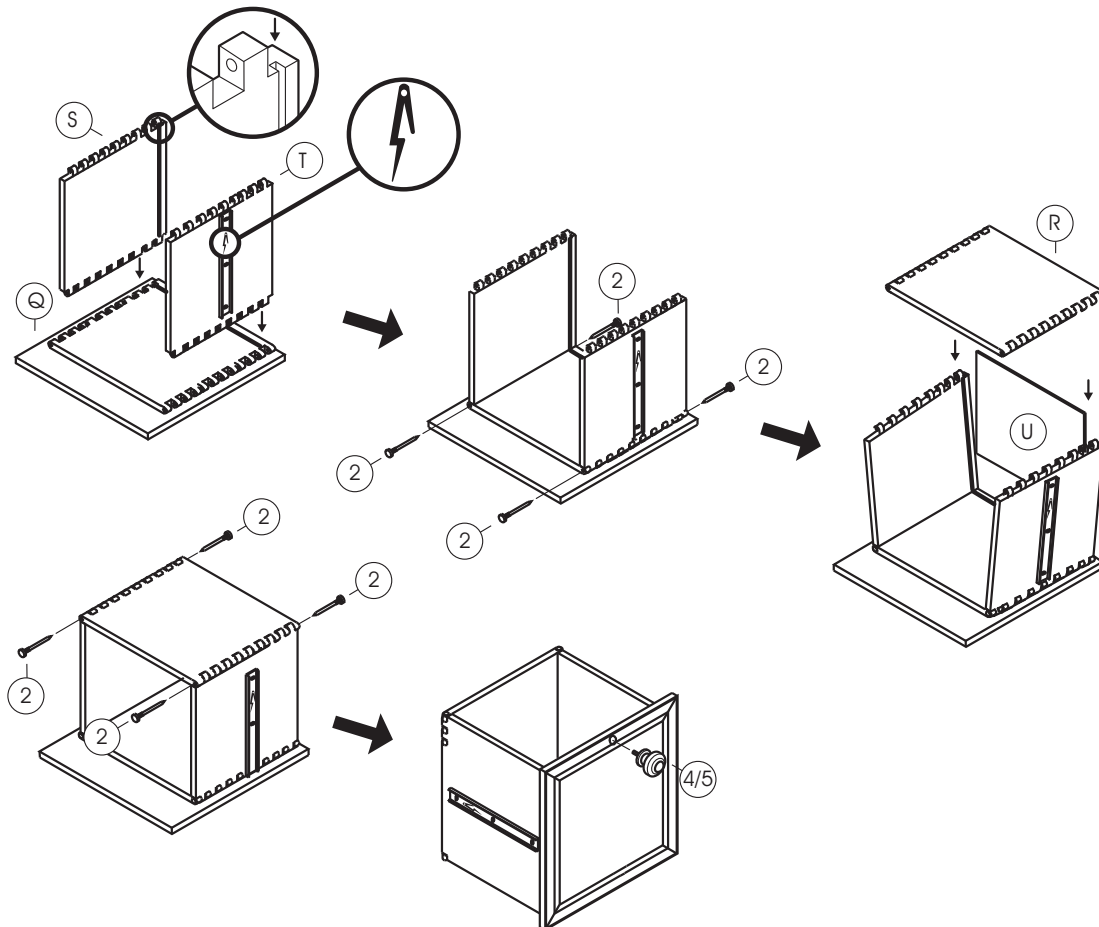

1. Connect left and right drawer panels (S) and (T) to front drawer panel (Q) using four drawer pins (2). Make sure black side latches are pointing forward.
2. Slide bottom drawer panel (U) into slots.
3. Connect rear drawer panel (R) to left and right panels using four drawer pins (2). If necessary, gently tap pins with a mallet or hammer until secure.
4. Select wood or metal knobs (4) or (5) and screw into front drawer panel.

NEED HELP? For help with assembly or if you are missing a part, please call the **Sauder Woodworking Co.** 1-800-523-3987 (7 a.m. to 5 p.m. PST).

Step 6: Assemble Right Drawer

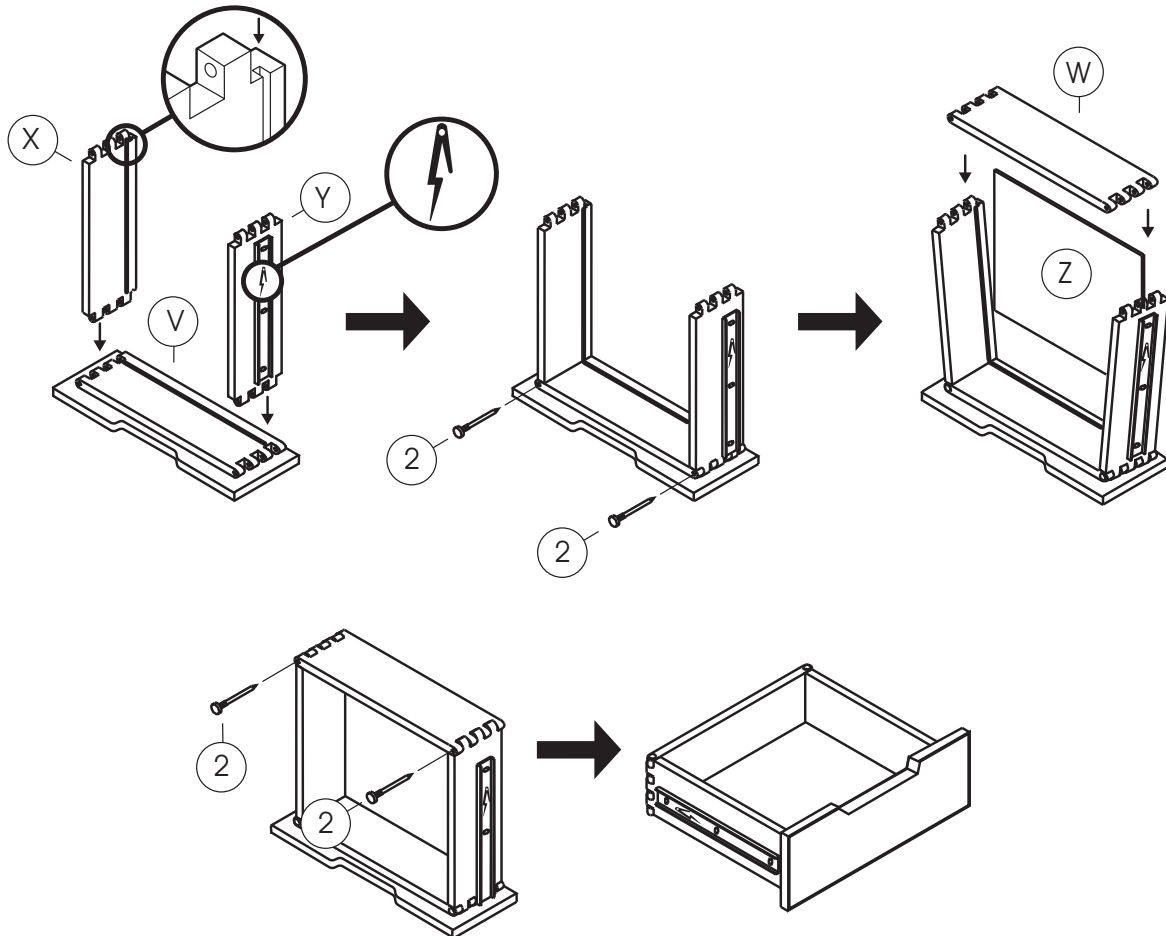
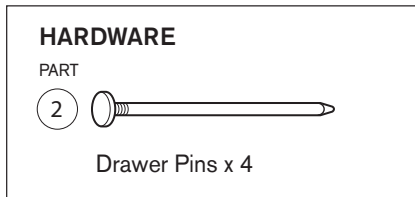

1. Connect left and right drawer panels (X) and (Y) to front drawer panel (V) using two drawer pins (2). Make sure black side latches are pointing forward. If necessary, gently tap pins with a mallet or hammer until secure.
2. Slide bottom drawer panel (Z) into slots.
3. Connect rear drawer panel (W) to left and right panels using two drawer pins (2). If necessary, gently tap pins with a mallet or hammer until secure.

NEED HELP? For help with assembly or if you are missing a part, please call the **Sauder Woodworking Co.** 1-800-523-3987 (7 a.m. to 5 p.m. PST).

Step 7: Attach the Top Panel

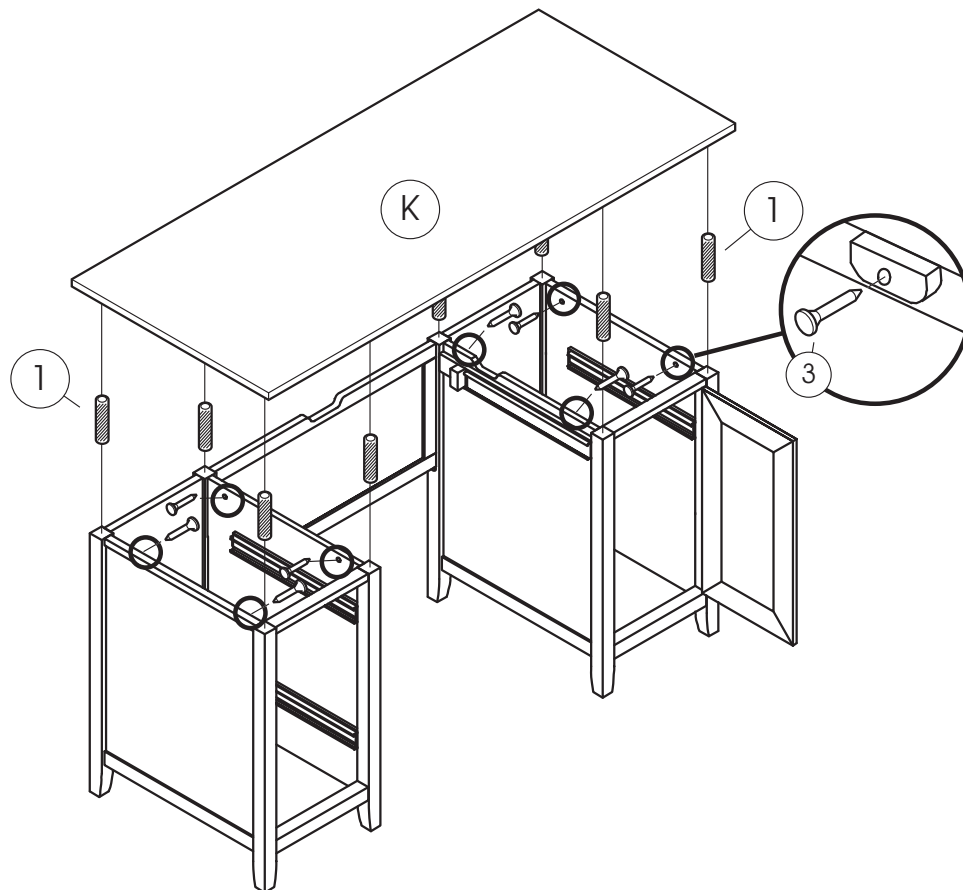
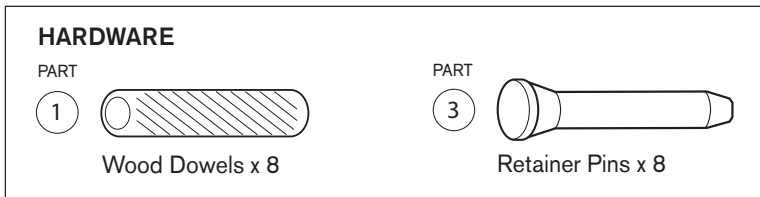

1. Insert a wood dowel ① into each of the eight holes in the panels.
2. Place top panel ① onto dowels and secure using eight retainer pins ③.

NEED HELP? For help with assembly or if you are missing a part, please call the **Sauder Woodworking Co.** 1-800-523-3987 (7 a.m. to 5 p.m. PST).

Step 8: Insert Drawers (Hooray! You're almost done!)

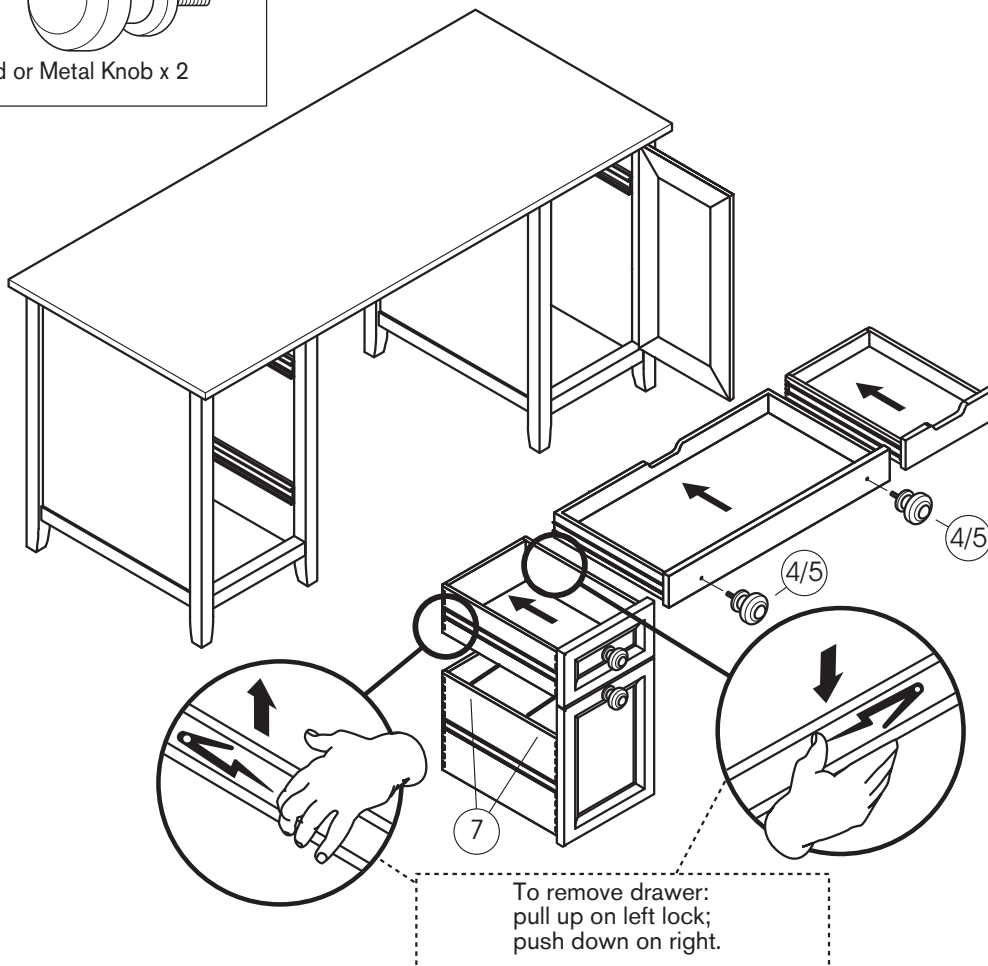
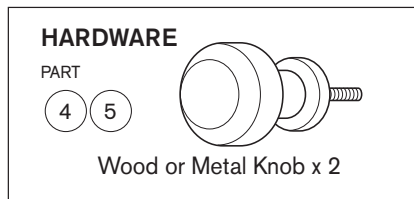

1. Select wood or metal knobs ④ or ⑤ and screw into front drawer panel.
2. To insert drawers, pull tracks on left and right sliders all the way forward (including ball bearing rack). Align tracks on drawer with sliders and push in the drawer.
3. Slowly open and close drawer several times to ensure a good connection. If drawer isn't sitting evenly, find the black locks on the sides of the drawer. Pull up on the left lock and push down on the right and pull out the drawer. Repeat step 1.
4. Insert file rods ⑦ into drawer.

NEED HELP? For help with assembly or if you are missing a part, please call the **Sauder Woodworking Co.** 1-800-523-3987 (7 a.m. to 5 p.m. PST).

Safety Precautions

Please review the following safety precautions to prevent personal injury or damage to the furniture:

Warning: This desk can hold a maximum weight of 200 lbs. (60 lbs in the file drawer and 25 lbs in the other drawers.) Do not exceed the maximum weight limit because it can damage the furniture and cause it to tip over.

For Your Child's Safety:

- Do not allow your children to climb or jump on furniture due to possible accident, injury or death.
- A child climbing on a piece of furniture can make it top-heavy and cause the furniture to tip over.

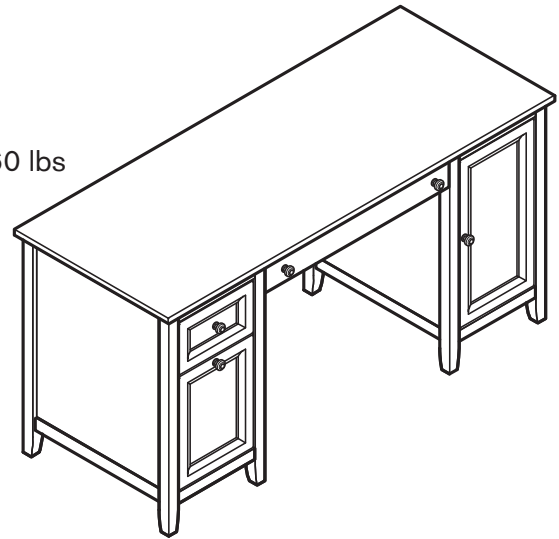

Bulky and Heavy Items:

- Use your desk appropriately. Do not overload drawers as it could cause personal injury or damage to the furniture.
- Never move or push heavy furniture by yourself because it can cause the furniture to tip over. Ask a friend to help you lift the furniture and set it in an appropriate place.

TV Safety:

- This desk is designed to be used as a desk only. It's not intended to support TVs or other heavy items.

Cleaning and Care for Your Canopy Furniture

- Use products specifically made for cleaning wood.
- Dust frequently with a soft dry cloth in the direction of the grain.
- Use a wood conditioning cleaner that does not contain waxes or silicones (test the product in an unseen location first).
- Clean spills immediately with a soft, damp cloth.
- Standing water can cause white spots on the wood finish.
- Chemicals such as alcohol, perfume, and medicines can cause severe damage to the wood finish.
- Protect wood surfaces by using coasters.
- Use a protective pad when using your furniture as a desk or writing surface (especially when using a ballpoint pen).
- Do not expose wood furniture to direct sunlight, drying heat sources or dampness.

NEED HELP? For help with assembly or if you are missing a part, please call the **Sauder Woodworking Co.** 1-800-523-3987 (7 a.m. to 5 p.m. PST).

LIMITED 1-YEAR WARRANTY

1. Sauder® furniture is warranted by Sauder Woodworking Co. (Sauder) to the original purchaser for a period of one year from the date of purchase against defects in the material or workmanship of furniture components. As used in this Warranty, “defects” mean imperfections in components, which substantially impair the utility of the product.
2. Under this Warranty, Sauder will (at its sole option) repair or replace a defective furniture component. As a condition of furnishing a replacement component claimed to be defective, Sauder may require independent confirmation of the claimed defect. Replacement parts will be warranted for only the remaining period of the original Warranty. This Warranty does not cover the cost of assembly or disassembly, transportation, labor, or any other incidental costs involved in the removal of a defective part or the installation of the replacement part.
3. This Warranty applies under conditions of normal use only. This Warranty does not apply to defects that result from accident, misuse or abuse, intentional damage, fire, flood, alteration or modification of the product, negligence, exposure, or use of the product in a manner inconsistent with its intended use. Sauder shall not be liable for any expense to repair or replace any item placed on, in, or around any Sauder furniture product.
4. This Warranty applies only as long as the product continues to be held for use by the original purchaser. The Warranty cannot be transferred to subsequent owners or users of the product, and it shall be immediately invalidated in the event that the product is resold, transferred, leased or rented to any third party or person other than the original purchaser.
5. THERE ARE NO OTHER EXPRESS WARRANTIES OTHER THAN AS SET FORTH ABOVE. FURTHERMORE, NO IMPLIED WARRANTY, INCLUDING, BUT NOT LIMITED TO, ANY IMPLIED WARRANTY OF MERCHANTABILITY OR FITNESS FOR A PARTICULAR PURPOSE, SHALL EXTEND BEYOND THE TERM OF THIS EXPRESS WARRANTY. Some states do not allow limitations on how long an implied warranty lasts, so the above limitation may not apply to you. SAUDER SHALL HAVE NO LIABILITY TO ANY PERSON FOR LOST PROFITS OR FOR ANY SPECIAL, CONSEQUENTIAL, INDIRECT, EXEMPLARY OR INCIDENTAL DAMAGES OF ANY KIND WHETHER ARISING IN CONTRACT, TORT, PRODUCT LIABILITY OR OTHERWISE. Some states do not allow the exclusion or limitation of incidental or consequential damages, so the above limitation or exclusion may not apply to you. This warranty gives you specific legal rights, and you may also have other rights which vary from state to state. Outside the USA, specific legal rights may vary depending on the country of residence of the original purchaser.
6. For warranty inquiries or claims, you may contact Sauder at 1-800-523-3987, e-mail us at www.sauder.com, or fax us at 419-446-3444. Sauder may require warranty claims to be submitted in writing to Sauder Woodworking Co., 502 Middle Street, Archbold, OH 43502 USA. Please include your sales receipt or other proof of purchase and a specific description of the product defect.